

Instruction Manual

Unique RV-ST Regulating Valve

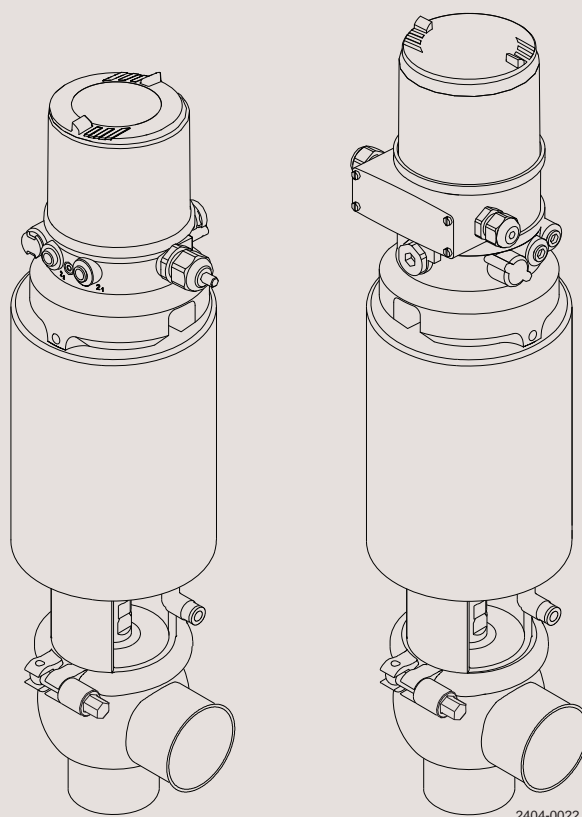

ESE02127-EN5

2016-06

Original manual

The information herein is correct at the time of issue but may be subject to change without prior notice

1. EC Declaration of Conformity	4
2. Installation	5
2.1. Important information	5
2.2. Warning signs	6
2.3. Safety precautions	7
3. Installation	9
3.1. Unpacking/delivery	9
3.2. General installation	10
3.3. Welding	12
3.4. Electrical connection	14
3.5. Recycling information	15
4. Operation	16
4.1. Operation	16
4.2. Troubleshooting	18
4.3. Recommended cleaning	19
5. Maintenance	21
5.1. General maintenance	21
5.2. Dismantling of valve	24
5.3. Plug seal replacement	25
5.4. Assembly of valve	29
5.5. Assembly instruction for positioner	29
5.6. Actuator types	30
5.7. Actuator bushing replacement	31
5.8. Dismantling of fully maintainable actuator (removable yoke with bolts/2006-June 2016) ..	36
5.9. Assembly of optional maintainable actuator	37
5.10. Mounting of fully maintainable actuator	37
5.11. Changing pneumatic movement on fully maintainable actuator (NC/NO)	38
6. Technical data	39
6.1. Technical data positioner	39
6.2. Technical data - valve/actuator	39
7. Parts list and service kits	42
7.1. Unique RV-ST Regulating Valve	42
7.2. Unique RV-ST Maintainable Actuator	44

1 EC Declaration of Conformity

Revision of Declaration of Conformity 2012-04-01

The Designated Company

Alfa Laval Kolding A/S

Company Name

Albuen 31, DK-6000 Kolding, Denmark

Address

+45 79 32 22 00

Phone No.

hereby declare that

Valve

Designation

Unique SSV PN10

Type

From serial number 5099880 to 29999999999

is in conformity with the following directive with amendments:

- Machinery Directive 2006/42/EC
- Pressure Equipment Directive 2014/68/EU kategori 1 and subjected to assessment procedure Module A. May only be used for fluids in Group 2

The person authorised to compile the technical file is the signer of this document

Global Product Quality Manager
Pumps, Valves, Fittings and Tank Equipment

Title

Lars Kruse Andersen

Name

Kolding

Place

2016-06-01

Date

Signature



Unsafe practices and other important information are emphasised in this manual.
Warnings are emphasised by means of special signs.

2.1 Important information

Always read the manual before using the valve!

WARNING

Indicates that special procedures must be followed to avoid serious personal injury.

CAUTION

Indicates that special procedures must be followed to avoid damage to the valve.

NOTE



Indicates important information to simplify or clarify procedures.

Different actuator types for the SSV valve

In June 2016 the below change was implemented and the “removable yoke with bolts” version is thereby phased out and replaced by the “yoke without bolts” version.

NOTE

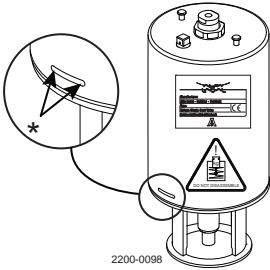
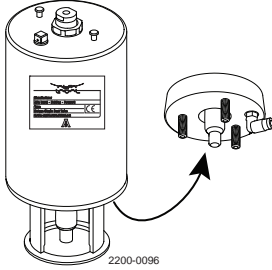
It is important to check for warnings marked on the actuator when servicing an actuator - see below table.

Actuator type	Non-maintainable actuator Spring under load and CANNOT be opened	Fully maintainable actuator Spring cage and can be opened	Fully maintainable actuator Spring cage and can be opened
	 <p>*) Lock wire opening is locked when warning is marked on actuator</p>		
Yoke type	Non-removable yoke	“Removable yoke with bolts”. If the yoke with bolts is damaged it has to be replaced by the “yoke without bolts”	“Yoke without bolts”
Service	Not possible to service internally (it is not possible to change piston o-rings)	Yes	Yes
Marked with warnings	Yes	No	No
Year of production	From 2006	From 2006 to June 2016	From June 2016

2 Installation

*Unsafe practices and other important information are emphasised in this manual.
Warnings are emphasised by means of special signs.*

2.2 Warning signs

General warning



Caustic agents



Danger of injury: (an extra yellow label marked on the actuator from June 2016)
Do **NOT** attempt to cut the actuator open due to spring under load.
(The lock wire opening is locked).

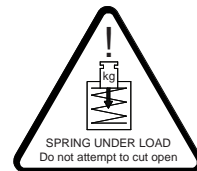

Danger of injury (lasermarked on the actuator)
Do **NOT** attempt to disassemble the actuator due to spring under load danger!
(The lock wire opening is locked)

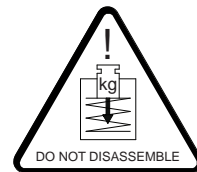

All warnings in the manual are summarised on this page.

Pay special attention to the instructions below so that serious personal injury and/or damage to the valve are avoided.

2.3 Safety precautions

Actuators

If support air is utilised:



- Shock in the actuator must **NEVER** occur
- Support air on high pressure actuator versions is **NOT** allowed

To prevent shock in the actuator and to prevent exceeding 10 bar product pressure, Alfa Laval recommends **NOT** to exceed 3 bar support air on the spring side in all the Unique SSV actuators.

Use the “3 bar air relief fitting” = 9611995903

Using the “3 bar air relief fitting” also extends the service life of the actuator piston O-ring.

If support air is connected then the following must be done:

- **Always** use the steel adapter (pos. 5) = 9614065301
Tighten torque 30 Nm
- **Always** use the 3 bar air relief fittings = 9611995903

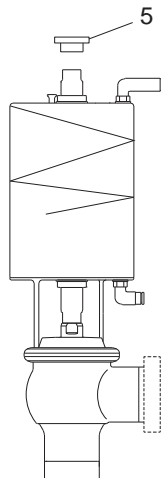

TD 461-990_2

Alfa Laval recommends max. 3 bar support air
Always use the “3 bar air relief fittings” on support air.
Alfa Laval article number = 9611995903

2 Installation

All warnings in the manual are summarised on this page.

Pay special attention to the instructions below so that serious personal injury and/or damage to the valve are avoided.

Installation

Always read the technical data thoroughly (see section 6 Technical data)

Always release compressed air after use

Never touch moving parts if the actuator is supplied with compressed air

Never touch the valve or the pipelines when processing hot liquids or when sterilising

Never dismantle the valve with valve and pipelines under pressure

Never dismantle the valve when it is hot



Never cut the actuator open, due to spring under load - if marked with this warning



Do **NOT** attempt to disassemble the actuator due to spring under load danger!



Operation

Never dismantle the valve with valve and pipelines under pressure

Never dismantle the valve when it is hot

Always read the technical data thoroughly (see section 6 Technical data)

Always release compressed air after use

Never touch the valve or the pipelines when processing hot liquids or when sterilising

Never touch moving parts if the actuator is supplied with compressed air

Always rinse well with clean water after cleaning



Always handle lye and acid with great care



Maintenance

Always read the technical data thoroughly (see section 6 Technical data)

Always release compressed air after use

Never service the valve when it is hot

Never service the valve with valve and pipelines under pressure

Never stick your fingers through the valve ports if the actuator is supplied with compressed air

Never touch moving parts if the actuator is supplied with compressed air

Always use Alfa Laval genuine spare parts



Never cut the actuator open, due to spring under load danger - if marked with this warning



Do **NOT** attempt to disassemble the actuator due to spring under load danger!



Transportation

Always ensure that compressed air is released

Always ensure that all connections are disconnected before attempting to remove the valve from the installation

Always drain liquid out of valves before transportation

Always use pre-designed lifting points if defined

Always ensure sufficient fixing of the valve during transportation - if specially designed packaging material is available, it must be used

The instruction manual is part of the delivery. Study the instructions carefully.
 The items refer to the parts list and service kits section.
 The valve is supplied as separate parts as standard (for welding).
 The valve is assembled before delivery, if it is supplied with fittings.

3.1 Unpacking/delivery

Step 1

CAUTION

Alfa Laval cannot be held responsible for incorrect unpacking.

Check the delivery for:

1. Complete valve
2. Delivery note
3. Instruction Manual

Step 2

Actuator version can be ordered either "fully maintainable" (no warning marked on actuator) or as "non-maintainable" (warning marked on actuator).

Non-maintainable actuator

Fully maintainable actuator

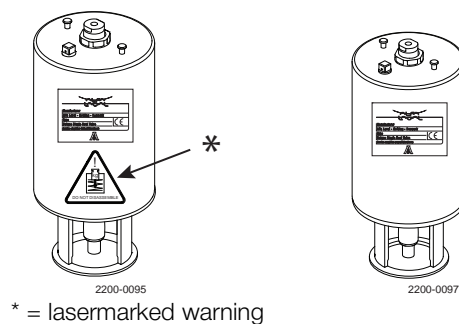

Step 3

1. Complete actuator
2. Bonnet (20)
3. Clamp (19)
4. Valve plug (23)
5. Valve body (22)
6. Positioner (77.1)
7. Adapter (82)
8. Spindle (79)
9. Special X-ring (80)
10. Allen screw (81)
11. Puck sensor pad (85)
12. O-ring (83)
13. Gasket for adapter (84)

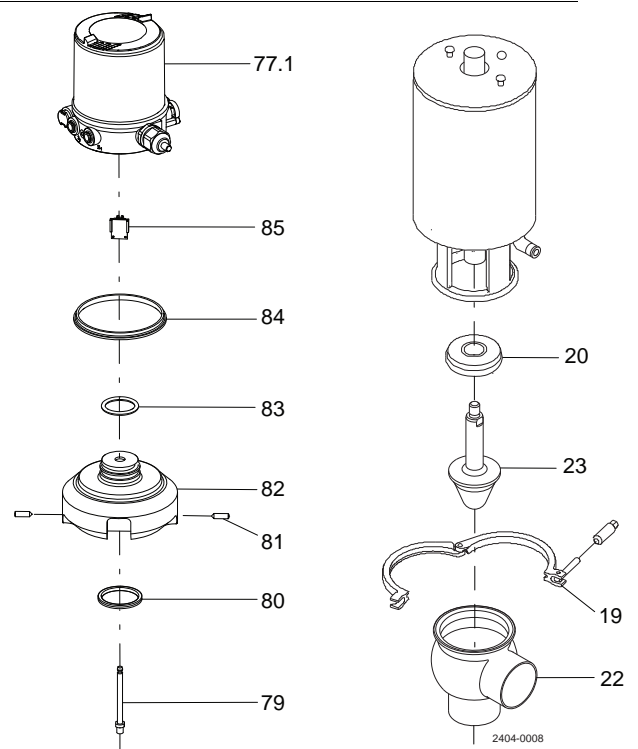

Step 4

Remove possible packing materials from the valve/valve parts.
 Inspect the valve/valve parts for visible transport damage.
 Avoid damaging the valve/valve parts.

3 Installation

Study the instructions carefully and pay special attention to the warnings!
The valve has welding ends as standard but can also be supplied with fittings.

3.2 General installation

Step 1



- **CAUTION**

- Alfa Laval cannot be held responsible for incorrect installation.
- **Always** release compressed air after use.
- **Always** read the technical data thoroughly.
See section .



Do **NOT** attempt to disassemble the actuator due to spring under load danger!



If marked with this warning, do **NOT** attempt to cut the actuator open, due to spring under load danger!

Step 2



Never touch the moving parts if the actuator is supplied with compressed air.

Moving parts!

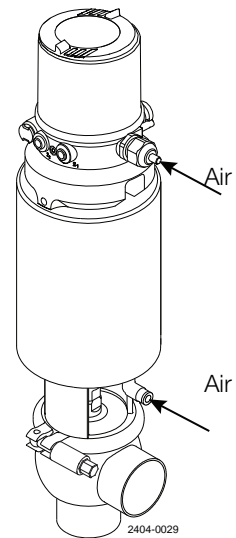

Step 3

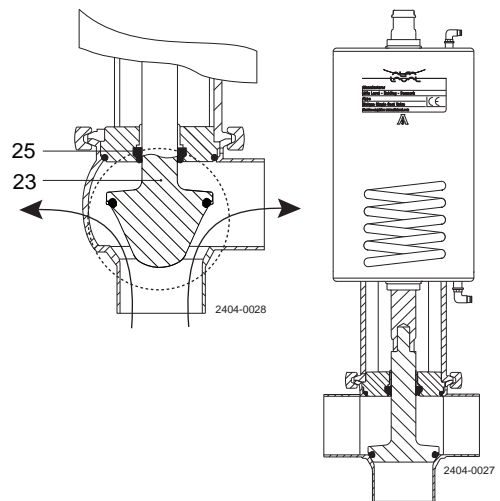

Study the instructions carefully and pay special attention to the warnings!
The valve has welding ends as standard but can also be supplied with fittings.

Step 4

Avoid stressing the valve.

Pay special attention to:

- Vibrations
- Thermal expansion of the tubes
- Excessive welding
- Overloading of the pipelines

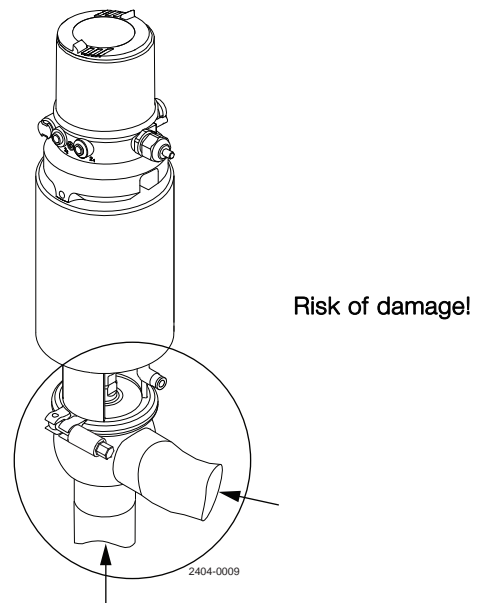

3 Installation

Study the instructions carefully.

The valve is supplied as separate parts to facilitate welding.

The items refer to the parts list and service kits section.

Check the valve for smooth operation after welding.

3.3 Welding

Step 1

Always install valves with more than one valve body so that the seals between the valve bodies can be replaced. Do not weld more than one valve body into the system.

Valve size	A (mm)	B (mm)
DN25/25 mm	*	630
DN40/38 mm	*	700
DN50/51 mm	*	750
DN65/63.5 mm	*	740
DN80/76 mm	*	800
DN100/101.6 mm	*	790

* Depending on body combination and piping solution.

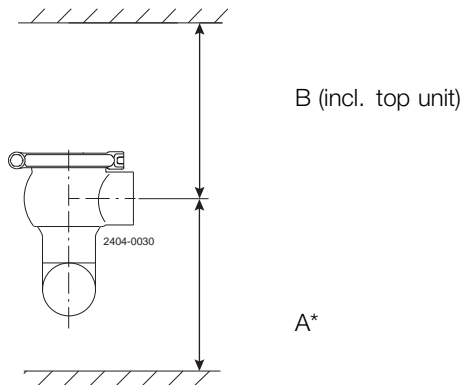

Step 2

Assemble the valve in accordance with the steps in chapter 5.4

Assembly of valve

Pay special attention to the warnings!

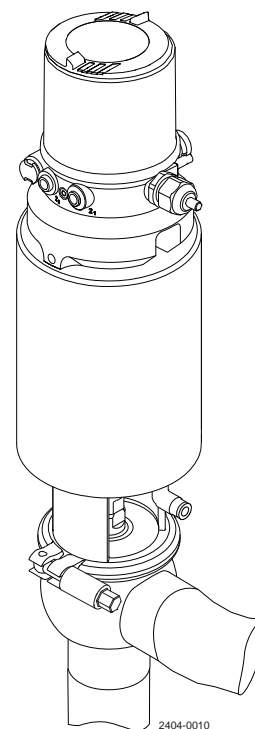

*Study the instructions carefully.
The valve is supplied as separate parts to facilitate welding.
The items refer to the parts list and service kits section.
Check the valve for smooth operation after welding.*

Step 3

Pre-use check:

1. Supply compressed air to the actuator.
2. Open and close the valve several times to ensure that it operates smoothly.

Pay special attention to the warnings!

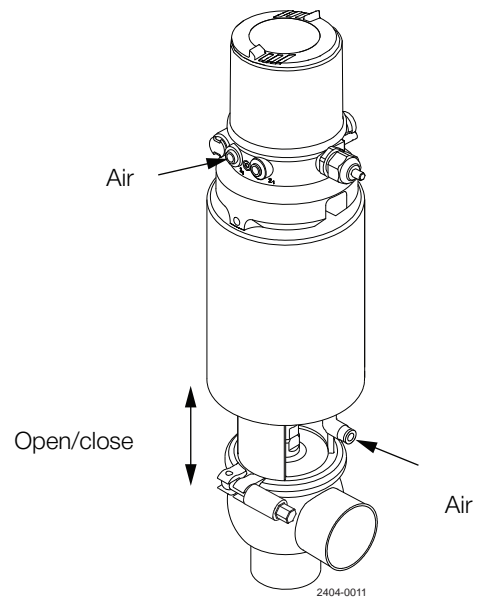

3 Installation

Study the instructions carefully.

The valve is supplied as separate parts to facilitate welding.

The items refer to the parts list and service kits section.

Check the valve for smooth operation after welding.

3.4 Electrical connection

Electrical connection

Positioner 8694
Without display
Terminal strip

Not connected	{	NC	1
		NC	2
		NC	3
PLC output signal	{	IN.0/4...20 mA +	4
		IN.0/4...20 mA GND	5
Power supply	{	Supply +	6
		Supply GND	7

Positioner 8692
With display
Terminal strip

Not connected	{	NC	1	} Not connected
		NC	2	
		NC	3	
		NC	4	
PLC output signal	{	SET. 0/4...20 mA GND	10	
		SET. 0/4...20 mA +	11	
Not connected	{	NC	12	
		Supply GND	13	
Power supply	{	Supply +	14	

Study the instructions carefully.

The valve is supplied as separate parts to facilitate welding.

The items refer to the parts list and service kits section.

Check the valve for smooth operation after welding.

3.5 Recycling information

• Unpacking

- Packing material consists of wood, plastics, cardboard boxes and in some cases metal straps
- Wood and cardboard boxes can be reused, recycled or used for energy recovery
- Plastics should be recycled or burnt at a licensed waste incineration plant
- Metal straps should be sent for material recycling

• Maintenance

- During maintenance, oil and wear parts in the machine are replaced
- All metal parts should be sent for material recycling
- Worn out or defective electronic parts should be sent to a licensed handler for material recycling
- Oil and all non-metal wear parts must be disposed in accordance with local regulations

• Scrapping

- At end of use, the equipment must be recycled according to relevant, local regulations. Besides the equipment itself, any hazardous residues from the process liquid must be considered and dealt with in a proper manner. When in doubt, or in the absence of local regulations, please contact your local Alfa Laval sales company



Do **NOT** attempt to disassemble the actuator due to spring under load danger!



If marked with this warning, do **NOT** attempt to cut the actuator open, due to spring under load danger!

4 Operation

Study the instructions carefully and pay special attention to the warnings!
Ensure that the valve operates smoothly.
The items refer to the parts list and service kits section.

4.1 Operation

Step 1



- **CAUTION**

- Alfa Laval cannot be held responsible for incorrect installation.
- **Always** release compressed air after use.
- **Always** read the technical data thoroughly.
See section 6 Technical data.
- **Always** use Alfa Laval genuine spare parts.
The warranty of Alfa Laval products is dependent on use of Alfa Laval genuine spare parts.



Do **NOT** attempt to disassemble the actuator due to spring under load danger!



If marked with this warning, do **NOT** attempt to cut the actuator with open, due to spring under load danger!

Step 2



Never touch the valve or the pipelines when processing hot liquids or when sterilising.

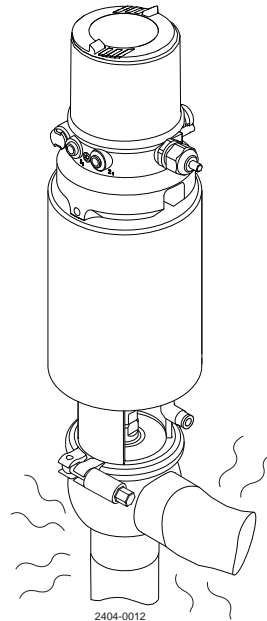

Danger of burns!

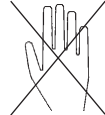

Study the instructions carefully and pay special attention to the warnings!
 Ensure that the valve operates smoothly.
 The items refer to the parts list and service kits section.

Step 3



Never touch moving parts if the actuator is supplied with compressed air.

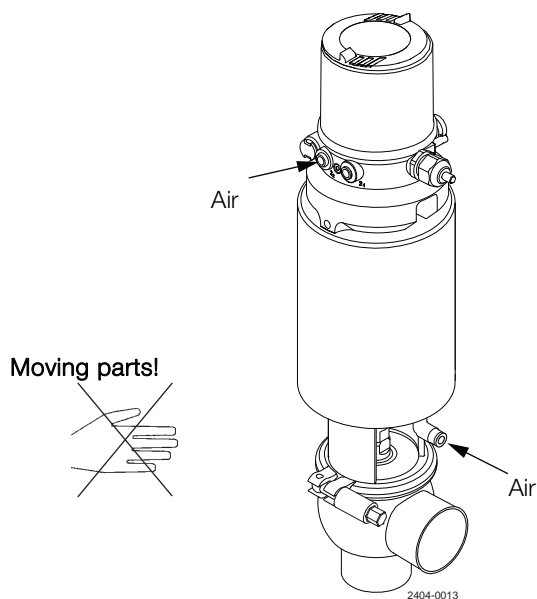

Step 4

Lubrication of valves:

1. Ensure smooth movement between lip seal (25) and plug stem (23).
2. Lubricate with Klüber Paraliq GTE 703 if necessary (see chapter 5.1 General maintenance).

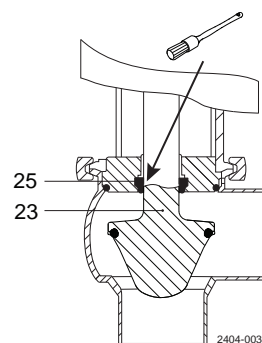

Step 5

Lubrication of actuator

1. Ensure smooth movement of the actuator (the actuator is lubricated before delivery).
2. Lubricate O-ring(s) with Molykote Longterm 2 plus if necessary.

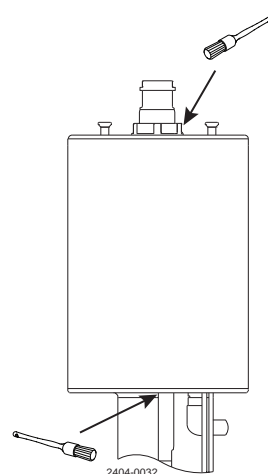

4 Operation

Pay attention to possible faults. Study the instructions carefully.
The items refer to the parts list and service kits (chapter 7 Parts list and service kits).

4.2 Troubleshooting

NOTE!

Study the maintenance instructions carefully before replacing worn parts. See chapter 5.1 General maintenance.

Problem	Cause/result	Repair
External product leakage	Worn or damaged lip seal and/or O-ring	<ul style="list-style-type: none"> - Replace the seals - Replace with seals of a different rubber grade
Internal product leakage	<ul style="list-style-type: none"> - Worn or product affected plug seal - Product deposits on the seat and/or plug - Product pressure exceeds actuator specification 	<ul style="list-style-type: none"> - Replace the seal - Replace with a seal of a different rubber grade - Frequent cleaning - Replace with a high pressure actuator - Use auxiliary air on the spring side (do not exceed 3 bar). Alfa Laval article number = 9611995903. See section 2.3 Safety precautions and section 3.2 General installation , Step 4 - Reduce product pressure
Water hammer	The flow direction is the same as the closing direction	<ul style="list-style-type: none"> - The flow direction should be against the closing direction. See section 3.2 General installation , Step 3 - Throttle air release of solenoid in top unit
The valve does not open/close	Product pressure exceeds actuator specification	<ul style="list-style-type: none"> - Replace with a high pressure actuator - Reduce product pressure - Use auxiliary air on the spring side. Always use the pressure relief fittings (3 bar) on support side. Alfa Laval article number = 9611995903

If marked with a danger warning, do **NOT** attempt to cut the actuator open, due to spring under load.



Do **NOT** attempt to disassemble the actuator due to spring under load danger!



Do **NOT** attempt to cut the actuator open due to spring under load danger!

The valve is designed for cleaning in place (CIP).
 NaOH = Caustic Soda.
 HNO₃ = Nitric acid.

4.3 Recommended cleaning

Step 1



Always handle lye and acid with great care.

Caustic danger!



Always use
rubber gloves!



Always use
protective goggles!

Step 2



Never touch the valve or the pipelines when sterilising.

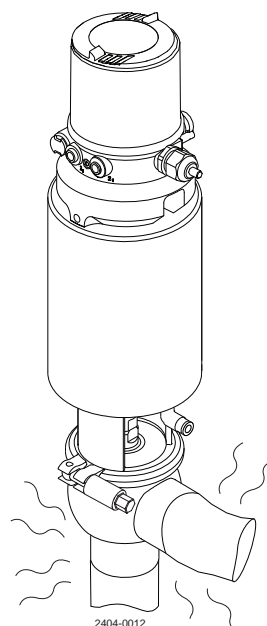

2404-0012

Danger of burns!

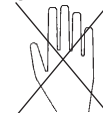

Step 3

Clean the plug and the seats correctly.
Pay special attention to the warnings!
Lift and lower valve plug momentarily!

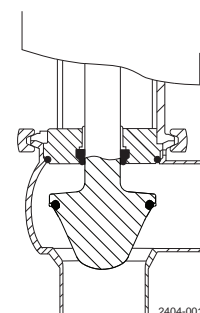

2404-0015

4 Operation

The valve is designed for cleaning in place (CIP).

NaOH = Caustic Soda.

HNO₃ = Nitric acid.

Step 4

Examples of cleaning agents:

Use clean water, free from chlorides.

1. 1% by weight NaOH at 70° C (158° F)

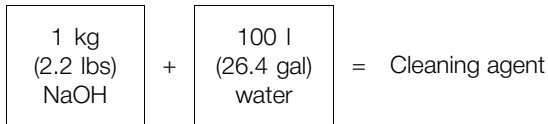

2. 0.5% by weight HNO₃ at 70° C (158° F)

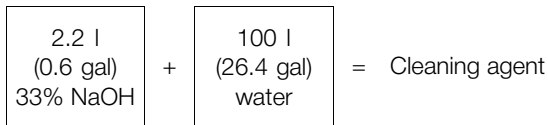
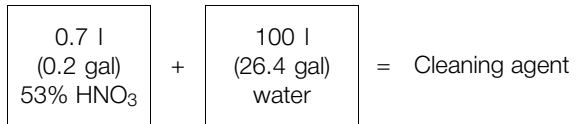

Step 5

1. Avoid excessive concentration of the cleaning agent.
2. Adjust the cleaning flow to the process.
3. **Always** rinse well with clean water after cleaning.

NOTE

The cleaning agents must be stored/disposed of in accordance with current regulations/directives.

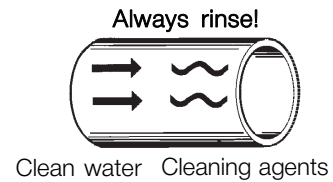

Maintain the valve regularly.

Study the instructions carefully and pay special attention to the warnings!

Always keep spare rubber seals and lip seals in stock.

Check the valve for smooth operation after service.

5.1 General maintenance

Step 1



- CAUTION

- Alfa Laval cannot be held responsible for incorrect installation.
- **Always** release compressed air after use.
- **Always** read the technical data thoroughly.
See section 6 Technical data.
- **Always** use Alfa Laval genuine spare parts.
The warranty of Alfa Laval products is dependent on use of Alfa Laval genuine spare parts.



Do **NOT** attempt to disassemble the actuator due to spring under load danger!



If marked with this warning, do **NOT** attempt to cut the actuator open, due to spring under load danger!

Step 2



Never service the valve when it is hot.

Never service the valve with valve and pipelines under pressure.

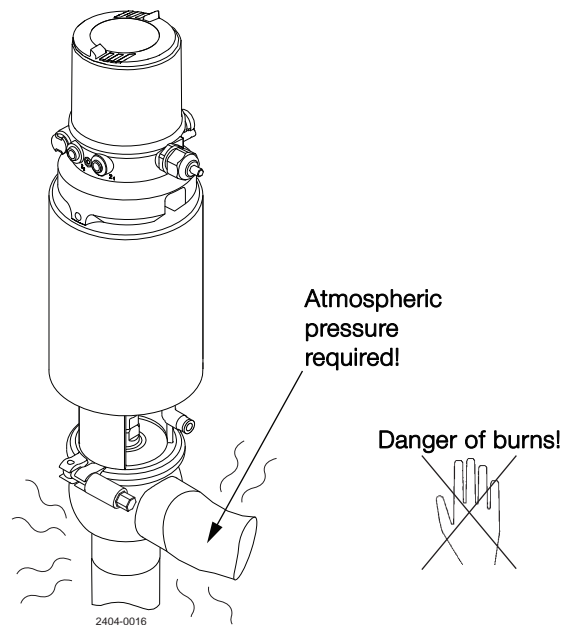

5 Maintenance

Maintain the valve regularly.

Study the instructions carefully and pay special attention to the warnings!

Always keep spare rubber seals and lip seals in stock.

Check the valve for smooth operation after service.

Step 3



Never stick your fingers through the valve ports if the actuator is supplied with compressed air.

Never touch the moving parts if the actuator is supplied with compressed air.

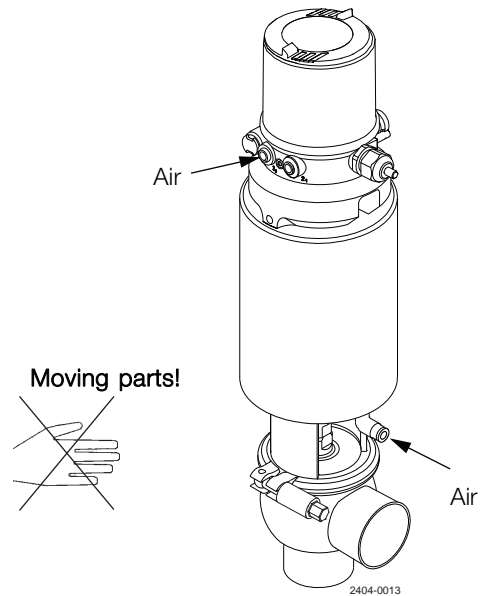

Maintain the valve regularly.
 Study the instructions carefully and pay special attention to the warnings!
 Always keep spare rubber seals and lip seals in stock.
 Check the valve for smooth operation after service.

Below are some guidelines for maintenance and lubrication intervals. Please note that the guidelines are for normal working conditions in one shift.

	Product wetted seals	Actuator bushings complete
Preventive maintenance	Replace after 12 months depending on working conditions	Replace after 5 years depending on working conditions
Maintenance after leakage (leakage normally starts slowly)	Replace at the end of the day	Replace when possible
Planned maintenance	<ul style="list-style-type: none"> - Regular inspection for leakage and smooth operation - Keep a record of the valve - Use the statistics for inspection planning Replace after leakage	<ul style="list-style-type: none"> - Regular inspection for leakage and smooth operation - Keep a record of the actuator - Use the statistics for inspection planning Replace after leakage
Lubrication	Before fitting Klüber Paraliq GTE 703 or similar USDA H1 approved oil/grease	Before fitting Molykote Longterm 2 plus

Pre-use check:

1. Supply compressed air to the actuator.
 2. Open and close the valve several times to ensure that it operates smoothly.
- Pay special attention to the warnings!**

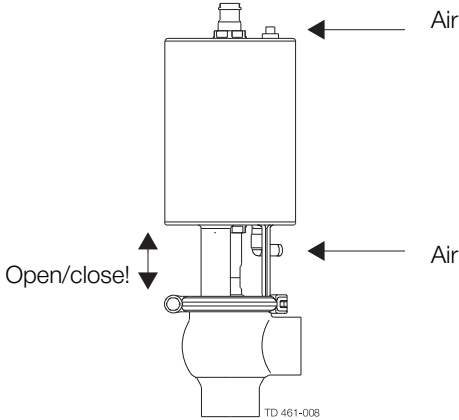

Recommended spare parts
 Service kits (see section)

5 Maintenance

Study the instructions carefully. The items refer to the parts list and service kits section. Handle scrap correctly.

NC = Normally closed.

NO = Normally open.

5.2 Dismantling of valve

If the actuator is marked with a danger warning, do **NOT** attempt to cut the actuator open.



Do **NOT** attempt to disassemble the actuator due to spring under load danger!



Do **NOT** attempt to cut the actuator open due to spring under load danger!

1. Supply compressed air to the actuator (only NC).
2. Loosen and remove clamp.
3. Release compressed air (only NC)
4. Lift away the actuator.
5. Unscrew and remove valve plug.
6. Remove O-ring, lip seal and bushing in bonnet. (Use bushing tool and rubber mallet).

Pay special attention to the warnings!

Note!

For plug seal replacement please see chapter 5.3 Plug seal replacement

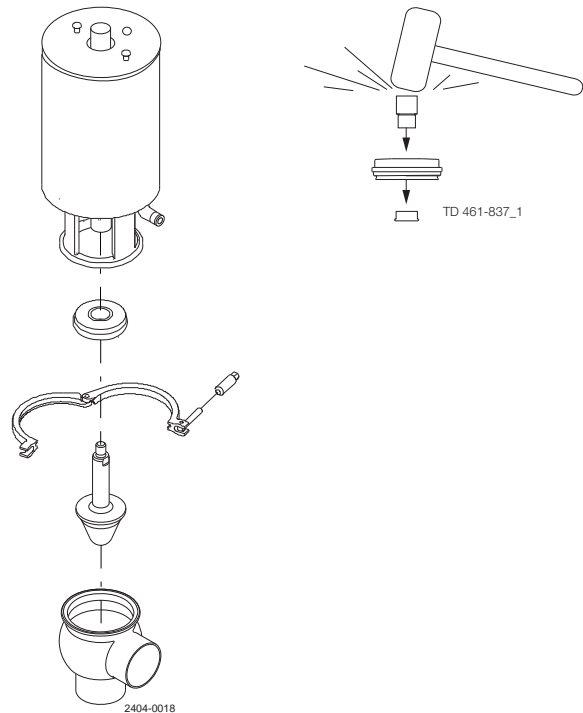

Study the instructions carefully. The items refer to the parts list and service kits section. Handle scrap correctly.

NC = Normally closed.

NO = Normally open.

5.3 Plug seal replacement

Step 1

1. Remove old seal ring using a knife, screwdriver or similar.
Be careful not to damage the plug surface.
If using a screwdriver it must be placed underneath the plug groove (see drawing 1).
2. Grease the new seal ring with Paralique GTE 703, which is included in the service kit.
Only use a very small amount of grease.
3. Fit the seal ring on the plug without pressing it into the groove.
Be careful not to twist the seal ring.
Use a screwdriver (two turns) to fit the seal ring properly and to ensure it is not twisted (see drawing 2).
4. The seal ring can now be mounted by hand or with the Alfa Laval plug tool.

Drawing 1

It is important to place the screwdriver underneath the plug.

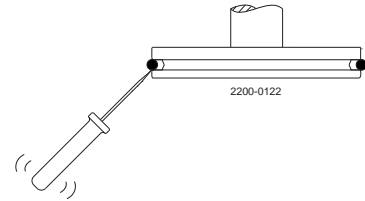

Drawing 2

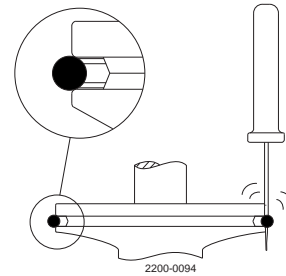

5 Maintenance

Study the instructions carefully. The items refer to the parts list and service kits section. Handle scrap correctly.

NC = Normally closed.

NO = Normally open.

Step 2

Mounting plug seal ring by hand

1. Check the seal ring is premounted as described in step 1.
To ensure correct mounting, press with your thumb on the seal ring, which must be done approximately 10 times and always with opposite pressure points, from A to B, to C and D (see drawing 3).
The rest of the seal ring can now be pressed into the groove so the whole seal ring is mounted. Check that there are NO "bulge" (see drawing 4).
If there is a little bulge – then use the screwdriver to eliminate the bulge.
Again press with the thumb on the seal ring and keep the pressure while rotating 360° (see drawing 3).
2. It is important to release compressed air behind the seal ring. This is done with a screwdriver and always underneath the plug as shown.
It must be done at one or two different points on the circumference.
Be careful not to make marks on the surface of the plug and seal ring (see drawing 5).

Drawing 3

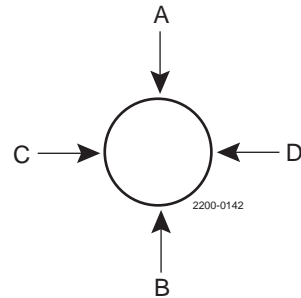

Drawing 4

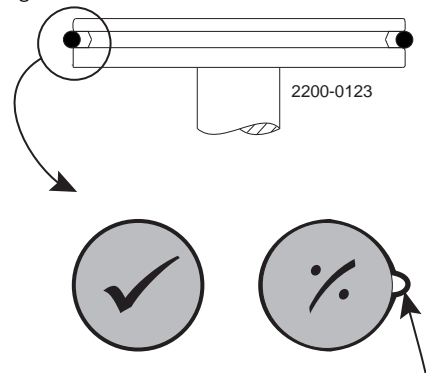

Drawing 5

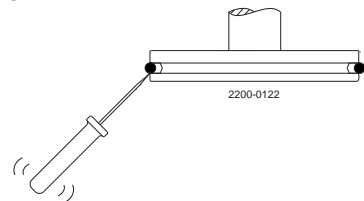

Study the instructions carefully. The items refer to the parts list and service kits section. Handle scrap correctly.

NC = Normally closed.

NO = Normally open.

Step 3

Mounting plug seal ring with Alfa Laval plug seal tool

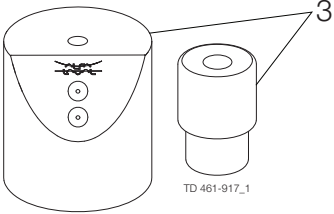
Mounting tool for elastomer plug seals	DN40 38 mm	DN50 - DN65 51 mm - 63.5 mm	DN80 - DN100 76.1 mm - 101.6 mm
 <p style="text-align: center; font-size: small;">TD 461-917_1</p>	9613172901	9613172902	9613172903

Exhaust holes
for screwdriver

ø20 hole
for plug spindle

1. Part B

“Part B” has a small and a large diameter as the tool can be used for two plug sizes – e.g. plug tool = 9613172902 can be used for DN50/ISO51 (small) and DN65/ISO63 (large).

“Part B” therefore has to be turned so it matches the plug size diameter.

2. Part A

“Part A” has an upper and lower exhaust hole, as the tool can be used for two plug sizes – e.g. plug tool = 9613172902.

The upper exhaust hole is for the small plug size e.g. DN50/ISO51 (small) and the lower exhaust hole is for DN65/ISO63 (large).

When using a “change-over plug” the ø20 spindle must also be fitted in “part A” and “part B” (see drawing 2).

When using a “reverse acting plug” the ø20 spindle must only be fitted in “part A” (see drawing 2).

When using a “standard shut-off plug” the ø20 spindle is only fitted in “part B” (see drawing 1).

3. Fit the plug spindle in “part B” or “part A”.

Place “part A” onto “part B” and then press “hard” down on top of “part A”.

Now fit the screwdriver into the exhaust hole and underneath the plug groove meanwhile keeping the pressure on “part A”. This should ensure correct removal of air behind the seal ring. Normally the sound “Psst” can be heard one time (see drawing 3).

A “drill press” can of course also be used to press down on “part A”.

4. It is important to release compressed air behind the seal ring. This is done with a screwdriver and always underneath the plug as shown (see drawing 4).

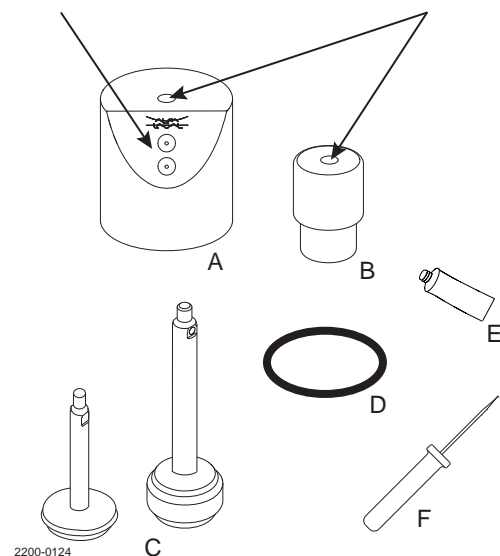

- A. Part A
- B. Part B
- C. Plugs
- D. O-ring
- E. Grease Paralique GTE703 from service kit
- F. Screwdriver (no sharp corner)

5 Maintenance

Study the instructions carefully. The items refer to the parts list and service kits section. Handle scrap correctly.

NC = Normally closed.

NO = Normally open.

Drawing 1

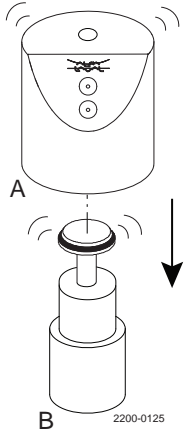

Drawing 2

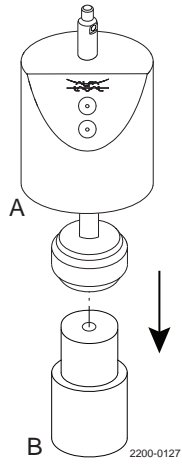

Drawing 3

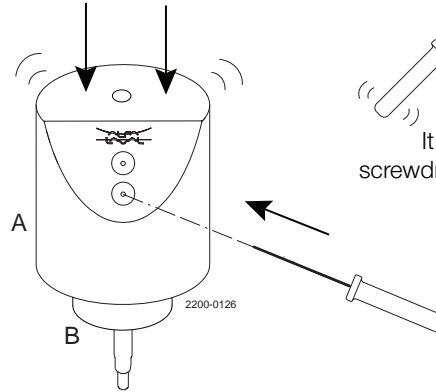

Drawing 4

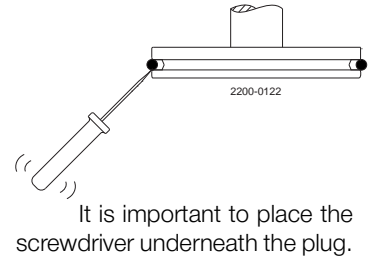

Study the instructions carefully. The items refer to the parts list and service kits section. Handle scrap correctly.

NC = Normally closed.

NO = Normally open.

5.4 Assembly of valve

Reverse order of .

Lubricate O-ring (21) and lip seal (25) with Klüber Paraliq GTE 703.

Remember to tighten spindle and plug to a torque of **30 Nm** (use two 17 mm spanners).

If there are vibrations in the pipeline, Alfa Laval recommends the use of Loctite no. 243.

The clamps' thread must be lubricated before tightening - max. torque for the clamps is 10-12 Nm.



Pay special attention to the warnings.

5.5 Assembly instruction for positioner

1. Mount the indication spindle (79) in top of actuator spindle (5).
2. Mount adapter (82) on top of actuator.
3. Fasten adapter by cross tighten the screws (81).
4. Mount the sensor pad (85) on the top of the indication spindle (79).
5. Remove top lid (a) and the cover (b) from positioner (77.1/77.2).
6. Grease seals lightly before assembly of the other parts with KlüberParaliq GTE 703.
7. Centring the sensor pad (85) in the guide rail inside the positioner when mounting the positioner unit (77.1/77.2) down over the adapter.
8. Fasten positioner (77.1/77.2) by cross tighten the screws.
9. Bring the actuator in top position (by using air if necessary).
10. Wire the electric connections according to "Quick start guide".
11. Assemble the cover (c) and the top lid (a) again.
12. Mount the actuator on the valve and make the settings according to "Quick start guide".

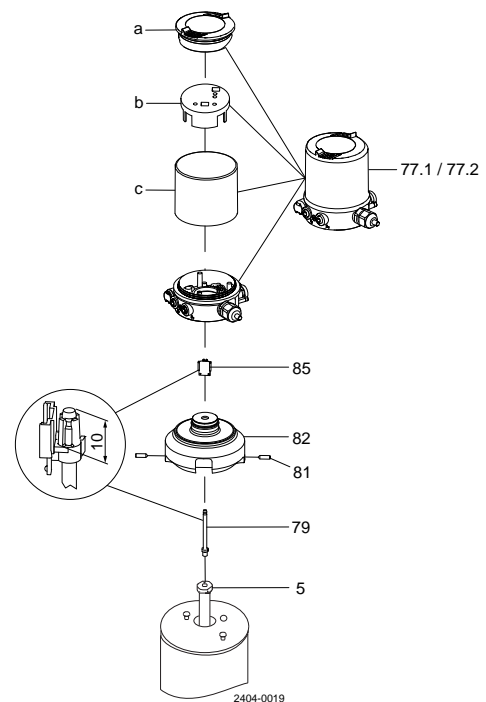

5 Maintenance

Study the instructions carefully. The items refer to the parts list and service kits section. Handle scrap correctly.

NC = Normally closed.

NO = Normally open.



5.6 Actuator types

Different actuator types for the SSV valve

In June 2016 the below change was implemented and the “removable yoke with bolts” version is thereby phased out and replaced by the “yoke without bolts” version.

NOTE

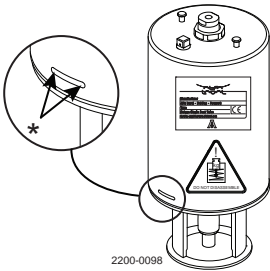
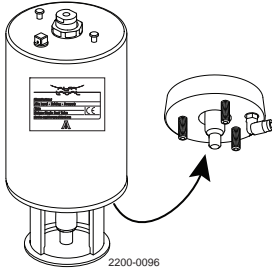
It is important to check for warnings marked on the actuator when servicing an actuator - see below table.

Actuator type	<p>Non-maintainable actuator Spring under load and CANNOT be opened</p>  <p>*) Lock wire opening is locked, when warning is marked on actuator</p>	<p>Fully maintainable actuator Spring cage and can be opened</p> 	<p>Fully maintainable actuator Spring cage and can be opened</p> 
Yoke type	Non-removable yoke	“Removable yoke with bolts”. If the yoke with bolts is damaged it has to be replaced by the “yoke without bolts”	“Yoke without bolts”
Service	Not possible to service internally (it is not possible to change piston o-rings)	Yes	Yes
Marked with warnings	Yes	No	No
Year of production	From 2006	From 2006 to June 2016	From June 2016

Study the instructions carefully. The items refer to the parts list and service kits section. Handle scrap correctly.

NC = Normally closed.

NO = Normally open.

5.7 Actuator bushing replacement

If the actuator is marked with a danger warning, do **NOT** attempt to cut the actuator open.



Do **NOT** attempt to disassemble the actuator due to spring under load danger!



Do **NOT** attempt to cut the actuator open due to spring under load danger!

Step 1

Introduction

- The actuator service kit contains two bushings and four o-rings.
- Mount the thick O-ring inside and the thin O-ring outside the bushing.
- Always lubricate the spindle and o-rings thoroughly with "Molykote Longterm 2 Plus" before mounting the new bushings.

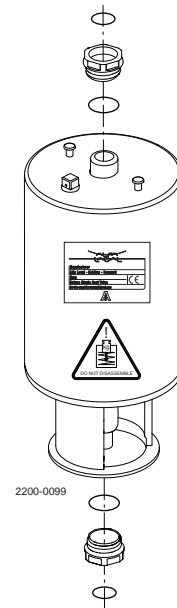

5 Maintenance

Study the instructions carefully. The items refer to the parts list and service kits section. Handle scrap correctly.

NC = Normally closed.

NO = Normally open.

Step 2

Introduction - Standard socket wrench

Use a 27 mm socket wrench to mount the bushings, as the space in the yoke is limited.

A socket wrench 24x27 (length = 185 mm) is a standard tool, which can be purchased from all tool shops.

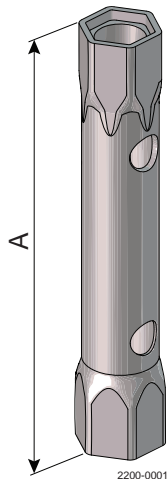

A = 185 mm

Example:
Socket wrench - 24x27 mm
Supplier: Gedore Tool
EAN4010886621264

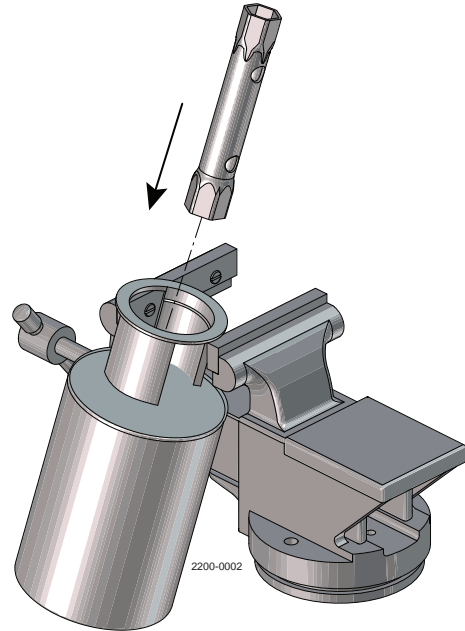

Step 3

Introduction - Aligning spindle

The actuator spindle can in some cases be forced off centre by the internal spring, see drawing below.

In these cases, the alignment spindle shown below, together with the socket wrench, is a great help and ensures a reliable mounting of the bushing. The spindle can either be purchased from Alfa Laval together with the socket wrench (9614-1984-01) or it can be manufactured locally using the below dimensions.

Spindle forced off centre by spring inside actuator

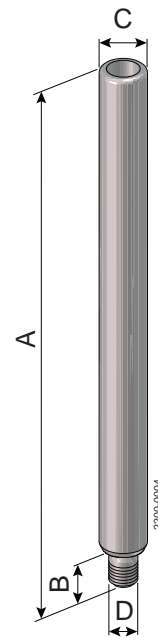
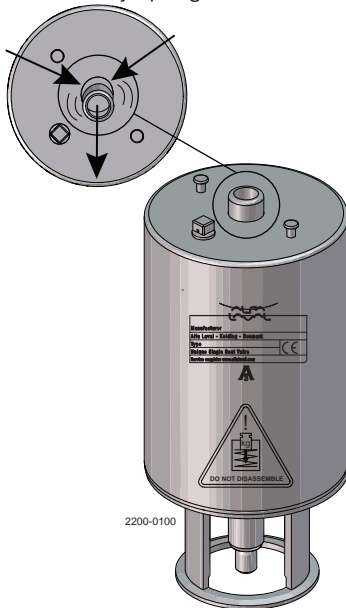

A = 280 mm
B = 16 mm
C = Rod \varnothing 20 mm
D = M12 x 1.5

Study the instructions carefully. The items refer to the parts list and service kits section. Handle scrap correctly.

NC = Normally closed.

NO = Normally open.

Step 4

The actuator must be carefully fixed in a vice if it is dismantled from the valve. Be careful not to press the yoke flange oval when fixing the actuator in the vice. Only fix carefully on the "yoke leg" as shown below.

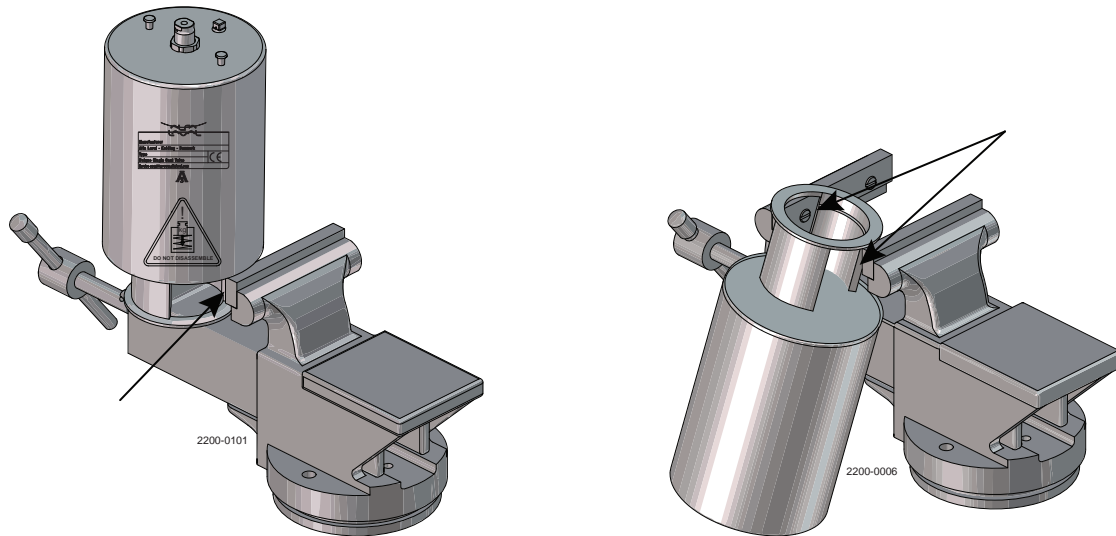

Step 5

Remove adapter screw.

(After spindle alignment the adapter screw has to be remounted.)

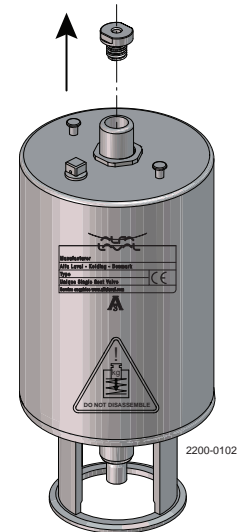

5 Maintenance

Study the instructions carefully. The items refer to the parts list and service kits section. Handle scrap correctly.

NC = Normally closed.

NO = Normally open.

Step 6

1. Lubricate thoroughly both the actuator spindle and o-rings.
2. Grease with "Molykote Longterm 2 plus".
3. Fit the **bushing** on the spindle.

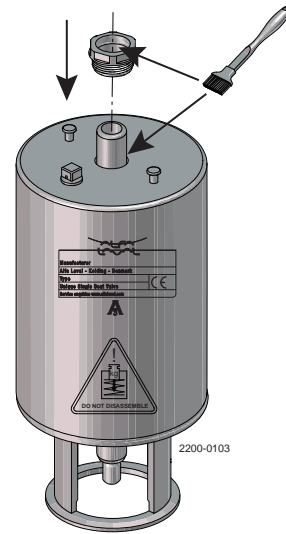

Step 7

Fit the aligning spindle to the actuator spindle, and then mount the socket wrench.

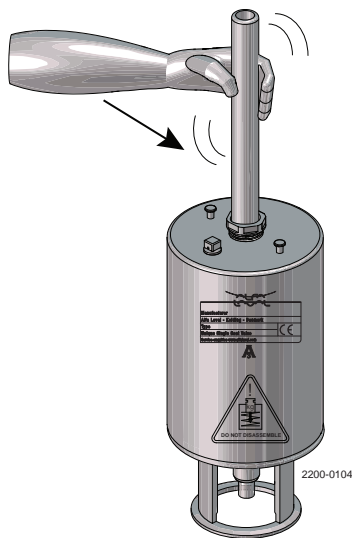

Aligning spindle

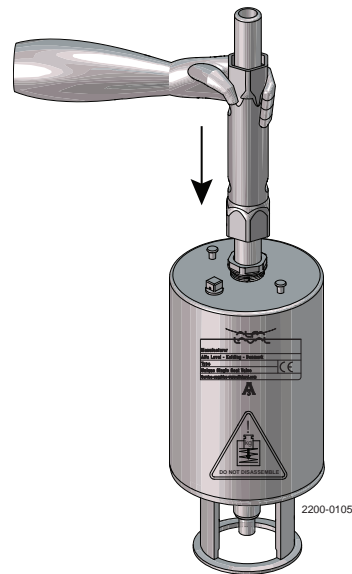

Socket wrench

Study the instructions carefully. The items refer to the parts list and service kits section. Handle scrap correctly.

NC = Normally closed.

NO = Normally open.

Step 8

Now pull the aligning spindle to centre the actuator spindle. In this position rotate the **bushing** 180° backwards and then begin to fasten the bushing. Make sure that the thread catches evenly!

The bushing must only be tightened with a torque of 10 Nm (7 lb-ft) which can be done by turning "hard" by hand.

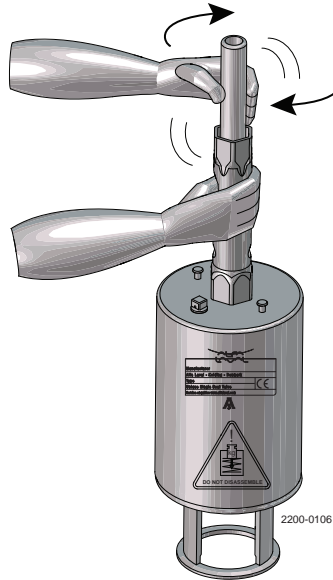

5 Maintenance

Study the instructions carefully. The items refer to the parts list and service kits section. Handle scrap correctly.

NC = Normally closed.

NO = Normally open.

5.8 Dismantling of fully maintainable actuator (removable yoke with bolts/2006-June 2016)

If the actuator is marked with a danger warning, do **NOT** attempt to cut the actuator open.

See also section 5.6 Actuator types



Do **NOT** attempt to disassemble the actuator due to spring under load danger!



Do **NOT** attempt to cut the actuator open due to spring under load danger!

Before dismantling check that the actuator not is marked with a warning.

1. Rotate cylinder.
2. Remove lock wire and pull away cylinder.
3. Unscrew nuts and remove yoke.
4. Top and bottom bushings.
5. Remove piston with O-ring and spring assembly.
6. Remove O-rings and support disc.

Rotate cylinder with service tool.

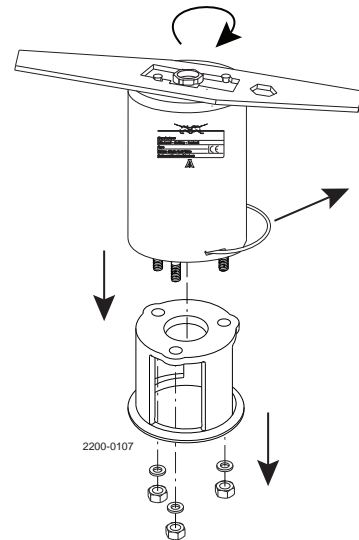

Note! The A/A actuator has no spring assembly.

Study the instructions carefully. The items refer to the parts list and service kits section. Handle scrap correctly.

NC = Normally closed.

NO = Normally open.

5.9 Assembly of optional maintainable actuator

If the actuator is marked with a danger warning, do **NOT** attempt to cut the actuator open.

See also section 5.6 Actuator types



Do **NOT** attempt to disassemble the actuator due to spring under load danger!



Do **NOT** attempt to cut the actuator open due to spring under load danger!

Before dismantling check that the actuator not is marked with a warning.

1. Rotate cylinder.
2. Remove lock wire and pull away cylinder.
3. Top and bottom bushings.
4. Remove piston with O-ring and spring assembly.

Rotate cylinder with service tool.

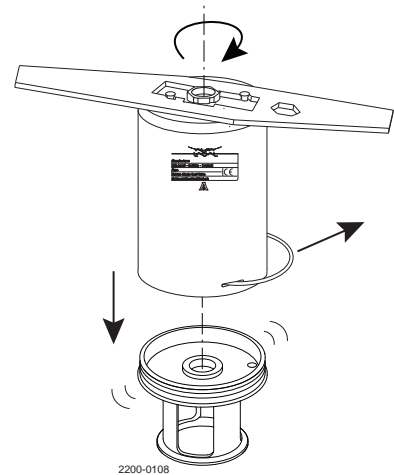

Note! The A/A actuator has no spring assembly.

5.10 Mounting of fully maintainable actuator

Depending on type of actuator choose step 1 or step 2.

Step 1

Reverse order of

Tighten nuts to a torque of 17 Nm.

Lubricate O-rings (3, 7, 11) with Molykote Longterm 2 plus before fitting.

Tighten bushings with a torque = 10 Nm and be careful not to overtightened. See also

Step 2

Reverse order of

Lubricate O-rings (3, 7, 11) with Molykote Longterm 2 plus before fitting.

Tighten bushings with a torque = 10 Nm and be careful not to overtightened. See also

5 Maintenance

Study the instructions carefully. The items refer to the parts list and service kits section. Handle scrap correctly.

NC = Normally closed.

NO = Normally open.

5.11 Changing pneumatic movement on fully maintainable actuator (NC/NO)

If the actuator is marked with a danger warning, do **NOT** attempt to cut the actuator open.

See also section 5.6 Actuator types.



Do **NOT** attempt to disassemble the actuator due to spring under load danger!



Do **NOT** attempt to cut the actuator open due to spring under load danger!

Before dismantling check that the actuator not is marked with a warning.

1. Rotate cylinder.
2. Remove lock wire and pull away cylinder.
3. Reverse piston and spring assembly.
4. Reverse adapter, air fitting and plug to opposite end.
5. Reassemble in reverse order (3 to 1).

NOTE

The A/A actuator has no spring assembly

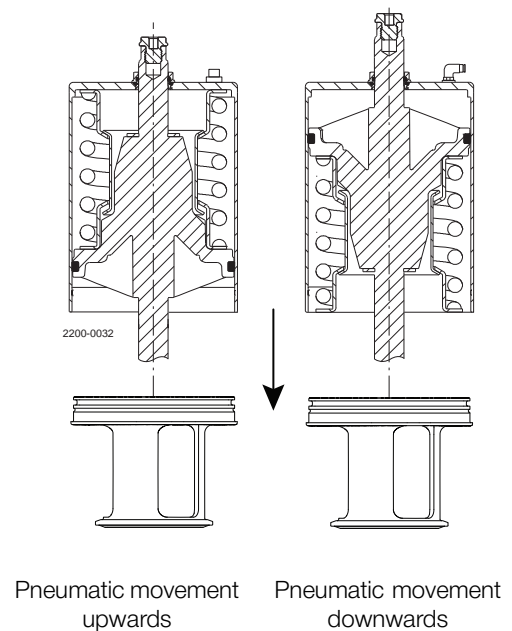

*It is important to observe the technical data during installation, operation and maintenance.
Inform personnel about the technical data.*

6.1 Technical data positioner

The valve is remote-controlled by a digital electro-pneumatic process controller. It has few and simple moveable parts which results in a very reliable valve.

Material:	
Body	PPS, Stainless Steel
Cover	PC
Sealing	EPDM
Power supply	24 VDC +/- 10%
Ripple	10%, no technical direct current
Setpoint setting	4 to 20 mA
Output resistance	180 Ω
Control medium:	
Neutral gases, air DIN ISO 8573-1	
Dust concentration	Class 5 (<40µm particle size)
Particle density	Class 5 (<10mg/m ³)
Pressure condensation point	Class 3 (<-20°C)
Oil concentration	Class 5 (<25mg/m ³)
Ambient temperature	0 to +60°C
Pilot air ports	Push-in connector (external ø6 mm or 1/4") or threaded ports G1/8
Supply pressure	Low air flow rate 5 to 7 bar ¹⁾
Air input filter	Exchangeable (mesh aperture~0.1mm)
Position detection module	Contact-free, wear-free
Stroke range valve spindle	3 to 28 mm
Installation	As required, preferably with actuator in upright position
Protection class	IP 65/67 according to EN 60529 (NEMA4x in preparation)
Power consumption	< 3.5 W
Electrical connection:	
Cable gland (in preparation)	1xM16x1.5 (cable-ø5-10mm), terminal screws (1.5 mm ²)
Protection class	3 according to VDE 0580
Conformity	CE acc. to EMC 2004/108/EC

1) The supply pressure has to be 0.5 - 1 bar above the minimum required pilot pressure for the valve actuator.

6.2 Technical data - valve/actuator

Data - valve/actuator	
Max. product pressure	10 bar (1000 kPa) (145 psi)
Min. product pressure	Full vacuum (depending on product specifications)
Temperature range	-10°C to + 140°C (standard EPDM seal)
Air pressure, actuator	5 to 7 bar (500 to 700 kPa) (72.5 to 101.5 psi)
Materials - valve/actuator	
Product wetted steel parts	AISI 316L (internal Ra < 0.8)
Other steel parts	AISI 304
Product wetted seals	EPDM (standard)
Optional product wetted seals	HNBR and FPM
Other seals	NBR

6 Technical data

*It is important to observe the technical data during installation, operation and maintenance.
Inform personnel about the technical data.*

Weight (kg)

Size	38 mm	51 mm	63.5 mm	76.1 mm	101.6 mm	DN 40	DN 50	DN 65	DN 80	DN 100
Weight (kg)	7.3	9.5	10.5	16.4	18.6	7.3	9.5	10.5	16.4	18.6

7 Parts list and service kits

It is important to observe the technical data during installation, operation and maintenance.
Inform personnel about the technical data.

7.1 Unique RV-ST Regulating Valve

If the actuator is marked with a danger warning do **NOT** attempt to cut the actuator open.



Do **NOT** attempt to disassemble the actuator due to spring under load danger!



Do **NOT** attempt to cut the actuator open, due to spring under load danger!

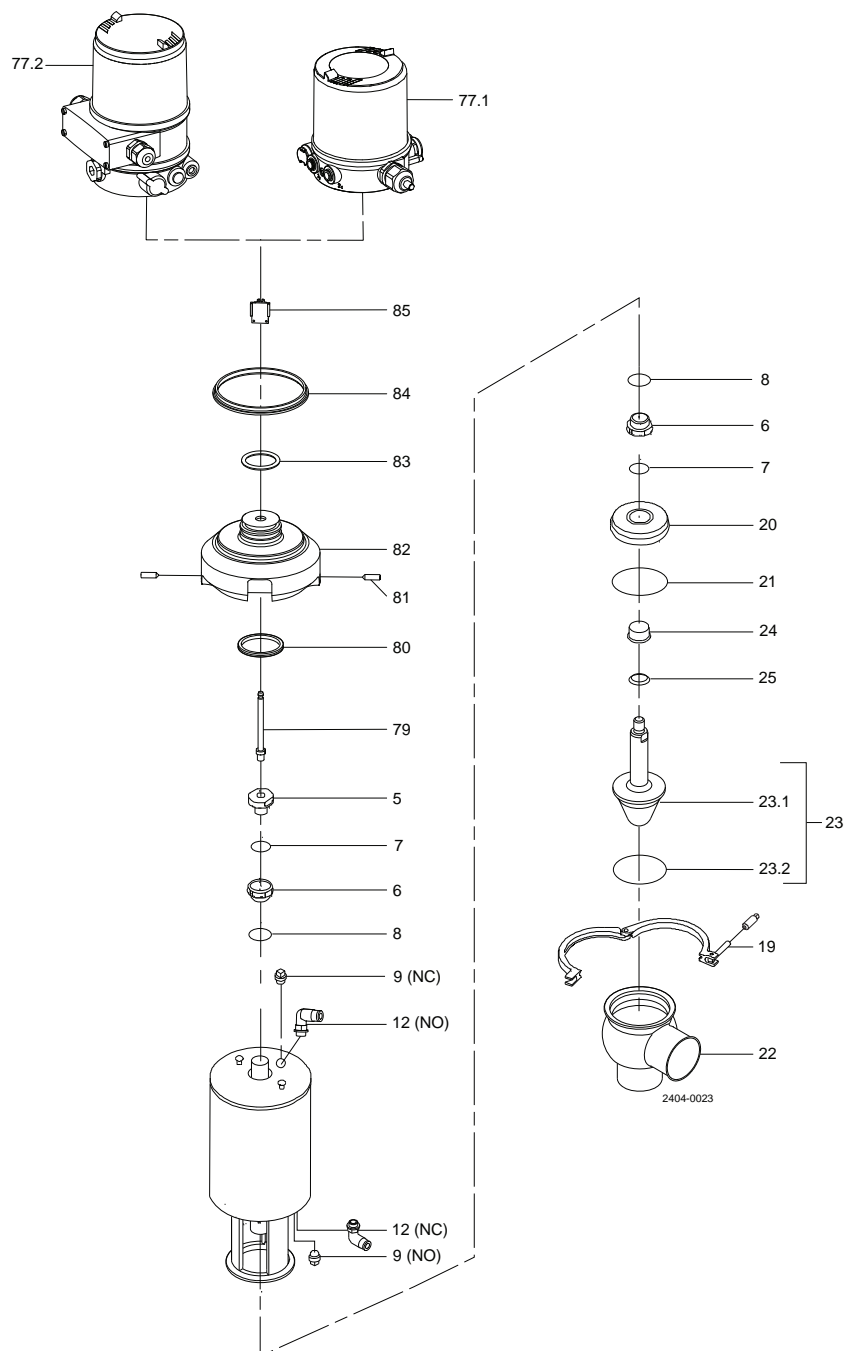

7 Parts list and service kits

*It is important to observe the technical data during installation, operation and maintenance.
Inform personnel about the technical data.*

Parts list

Pos.	Qty	Denomination
5	1	Adapter
6 •	2	Bushing
7 •	2	O-ring
8 •	2	O-ring
9	1	Plug
12	1	Air fitting
19	1	Clamp
20	1	Bonnet
21 □	1	O-ring
22	1	Valve body, lower
23	1	Plug, complete
23.1	1	Plug
23.2 □	1	Plug seal
24	1	Bushing
25 □	1	Lip seal
76	1	Positioner
78	1	Adapter
79	1	Spindle
80	1	Special X-ring
81	2	Allen screw
82	1	Adapter
83	1	O-ring
85	1	Puck sensor pad, cpl.

Service kits

Denomination	DN40 38 mm	DN50 51 mm	DN65 63.5 mm	DN80 76.1 mm	DN100 101.6 mm
• Service kit, actuator	9611926500	9611926500	9611926500	9611926500	9611926500
□ Service kit, EPDM	9611926502	9611926503	9611926504	9611926505	9611926506
□ Service kit, HNBR	9611926508	9611926509	9611926510	9611926511	9611926512
□ Service kit, FPM	9611926514	9611926515	9611926516	9611926517	9611926518

Parts marked with • are included in the service kits (actuator)

Parts marked with □ are included in the service kits (product wetted parts)

Tool for bushing (pos. 24) 9613160901

TD 900618/3

7 Parts list and service kits

It is important to observe the technical data during installation, operation and maintenance.
Inform personnel about the technical data.

7.2 Unique RV-ST Maintainable Actuator

If the actuator is marked with a danger warning do **NOT** attempt to cut the actuator open.



Do **NOT** attempt to disassemble the actuator due to spring under load danger!



Do **NOT** attempt to cut the actuator open, due to spring under load danger!

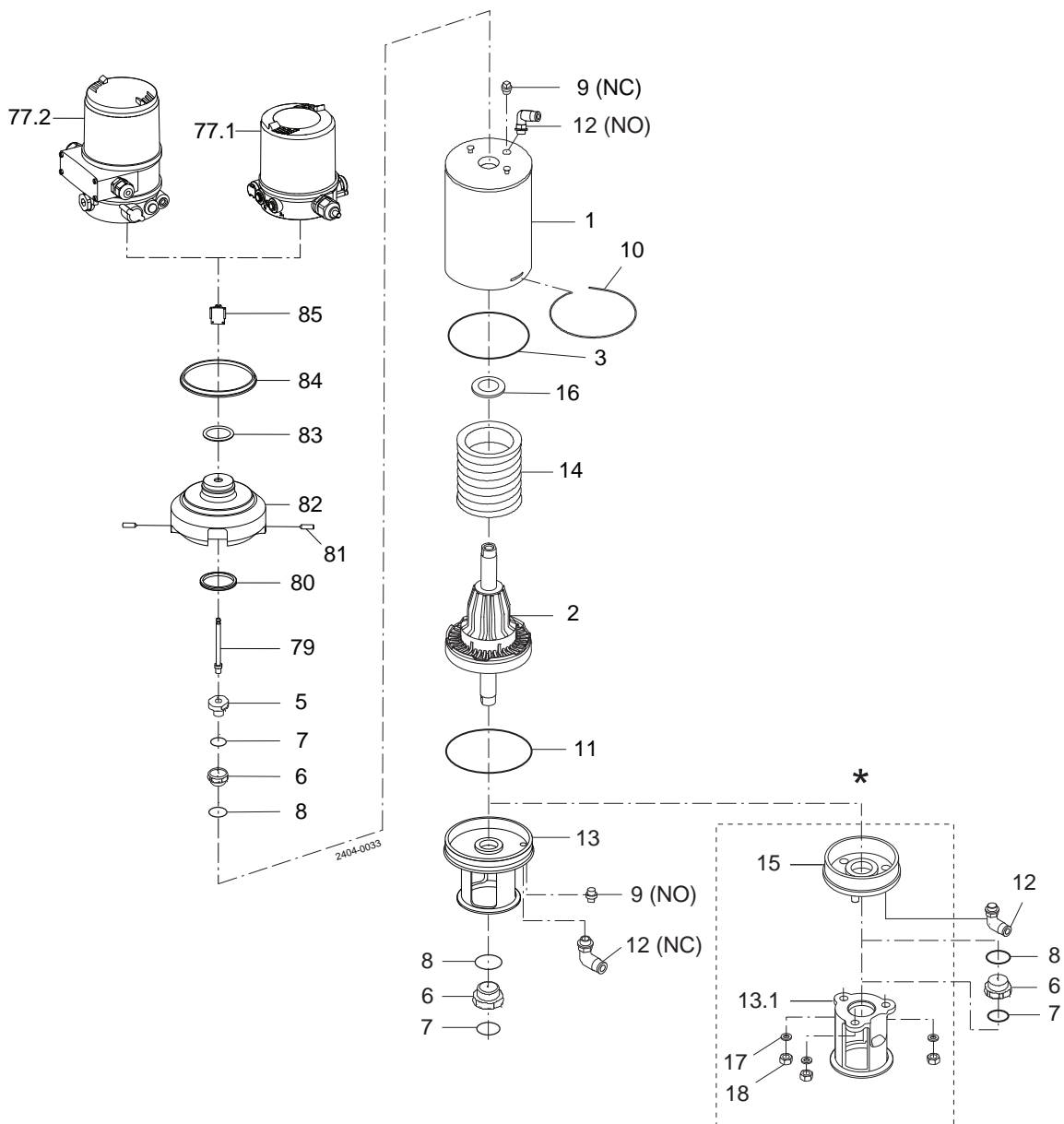

*) "Removable yoke bolts" version, product from 2006 to June 2016.
Replaced by "yoke without bolts" (13)

7 Parts list and service kits

*It is important to observe the technical data during installation, operation and maintenance.
Inform personnel about the technical data.*

Parts list

Pos.	Qty	Denomination
1	1	Cylinder
2	1	Piston
3 ●	1	O-ring
5	1	Adaptor
6 ●	2	Bushing
7 ●	2	O-ring
8 ●	2	O-ring
9	1	Plug
10	1	Lock wire
11 ●	1	O-ring
12	1	Air fitting
13	1	Yoke without bolts
13.1	1	Yoke (- 0616)
14	1	Spring assembly
15	1	Bottom (- 0616)
16 ●	1	Support disc
17	3	Washer (- 0616)
18	3	Nut (- 0616)
79	1	Spindle
80	1	Special X-ring
81	2	Allen screw
82	1	Adapter
83	1	O-ring
84	1	Gasket for adapter
85	1	Puck sensor pad, cpl.

Service kits

Denomination	DN40 38 mm	DN50 51 mm	DN65 63.5 mm	DN80 76.1 mm	DN100 101.6 mm
● Service kit, Actuator	9611926497	9611926498	9611926498	9611926499	9611926499

Parts marked with ● are included in the service kits (actuator)

Recommended spare parts: Service kits.

TD900619/4

How to contact Alfa Laval

Contact details for all countries are continually updated on our website.

Please visit www.alfalaval.com to access the information directly.

© Alfa Laval Corporate AB

This document and its contents is owned by Alfa Laval Corporate AB and protected by laws governing intellectual property and thereto related rights. It is the responsibility of the user of this document to comply with all applicable intellectual property laws. Without limiting any rights related to this document, no part of this document may be copied, reproduced or transmitted in any form or by any means (electronic, mechanical, photocopying, recording, or otherwise), or for any purpose, without the expressed permission of Alfa Laval Corporate AB. Alfa Laval Corporate AB will enforce its rights related to this document to the fullest extent of the law, including the seeking of criminal prosecution.